

Gear Box Cl.4-5

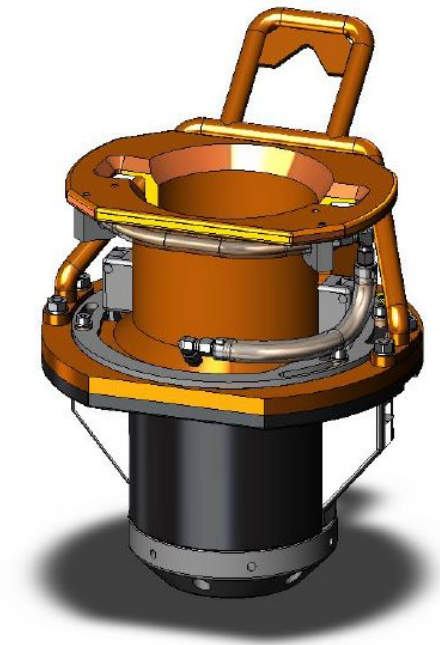

The Tool is able to operate in a torque range from 750 Nm up to 7000 Nm. It is designed to interface with an ISO 13628-8 Class 5 receptacle, and is equipped with an ISO 13628-8 Class 4 receptacle for external torque input.

Specifications

Size (w/o ROV Handle)	Ø = 340 mm x L= 373 mm
Weight in air/water	37 kg / 28 kg
Weight Transport Box complete	47 kg
Depth rating	3000 m
Oil-Volume	300 ml
Gear Ratio	1:3.22
Torque Input	300 – 1.950 Nm
Torque Output	750 – 7.000 Nm
Torque Input Interface	ISO 13628-8 Class 4
Torque Output Interface	ISO 13628-8 Class 5
ROV Manipulator Interface	ROV Handle (For Tool lifting/handling) Latch Guide Ring Handles (For operating latches)
Transport Box size	800 mm x 600 mm x 400 mm