

# DRAGONFISH™

## OTAQ – Precision Underwater Laser Measurement



The DragonFish is a highly compact and rugged underwater laser measurement and profiling system with topside video and software analysis. The system has been designed for a wide range of subsea measurement applications including the width and depth of cracks and gaps, pipeline radius, diameter and circumference and precise distance and angular measurements.

Depending on the range to target, the DragonFish generates results with an accuracy of up to 0.5 mm. The package is very compact and has been designed to integrate to the smallest of ROV systems or it can be modified for diver use using the attachable handle.

The system is supplied with offshore proven operating software for target measurements and analysis. It generates results in real time so does not require costly data post processing and does not require input from survey. DragonFish is easy to operate with remote training completed in 1 to 2 hours, typically the system does not require an offshore technician.

### Specifications

Technology	Laser Calliper laser measurement and profiling with video and software analysis
Market	Offshore Energy, Underwater Archaeology, Oceanographic Research, Nuclear Energy
Applications	Any underwater task where highly accurate measurement and profiling is required Provides sub millimetric point to point measurements and profiling of shapes, enabling diameter, circumference, radius, angle, distance. Ideal for weld seams, mooring chains, depletion, integrity, impact damage
Models	Driver held and ROV mount Harsh environment proven, reliable, compact and easy to use Enables measurement up to 0.5mm accuracy
Notes	Does not require INS / positioning input from Survey No offshore technician or data related post processing costs

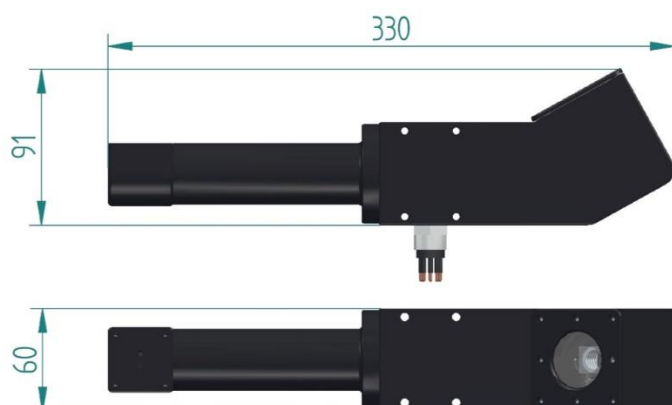

Model	DragonFish DH	DragonFish RM
Max range	100-2000 mm	100-2000 mm
Accuracy	Up to 0.5 mm	Up to 0.5 mm
Resolution	Up to 0.3 mm	Up to 0.3 mm
Laser wavelength	450 nm (blue)	450 nm (blue)
Laser power	70mW	70mW
Fan angle	45°	45°
Depth rating	300 m	3000 m
Weight air/water	0.5 kg / 0.3 kg	0.5 kg / 0.3 kg
Power	250mA @ 24 VDC	250mA @ 24 VDC
Housing material	Anodised aluminium	Anodised aluminium
Topside	Software GUI, laptop	Software GUI, laptop