

Upright Flying Lead Orientation Tool

ROV Tools.

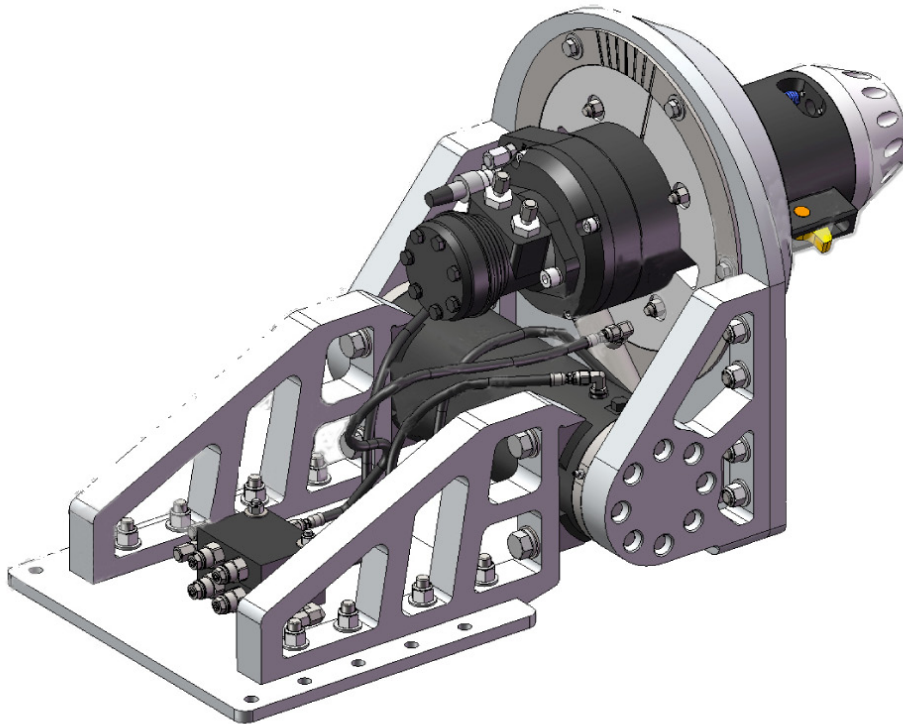

DESCRIPTION

The FLOT tool is designed to operate in conjunction with a torque tool and is used to orientate and guide flying leads into the stab plate connections. The FLOT tool is designed to take the FORUM Class 1-4 torque tool, but can easily accommodate similar tools from other manufacturers. A rotary actuator allows a pitch alignment of plus 60 or minus 90 degrees with a load of up to 250kg attached. The tool is also equipped with a roll alignment function giving a rotation of plus or minus 15 degrees.

The FLOT tool is compact and the tool mounting base is supplied with a selection of mounting holes for mounting within the forward structure of the ROV. The pitch and roll actuators are controlled from the ROV's spare directional control valves.

FEATURES

- +/- 15 deg roll angle
- plus 60 minus 90 deg pitch
- Counterbalance Valve on both actuators.
- 250kg Payload
- Supplied in offshore suitable transit case.

Upright Flying Lead Orientation Tool

ROV Tools.

SPECIFICATIONS

Weight in air/water:	77 kg/57 kg (169 lbs/125lbs)
Pitch:	(excl torque tool)
Rotation:	+60,- 90 degrees
Payload Capacity:	+/- 15 degrees
Hydraulic control from ROV:	250kg (550lb) mounted on torque tool, through full range of travel.
Operating Fluid:	Two off bi directional solenoid control valves plus drain
Operating Pressure:	Hydraulic Oil
Hydraulic Fittings:	207 bar (3000 psi) JIC or Swagelok

WHAT'S IN THE BOX

Flying Lead Orientation Tool
 Adaptor to fit Forum Torque Tool
 Supply and return hoses.
 Operations & Maintenance Manual.

PART NUMBERS & OPTIONS

TL0017-0000-00	Upright Flying Lead Orientation Tool
TL0017-0800-00	Basic Spares Kit
TL0017-5000-00	Extending Deck for flying lead tool
TL0017-2000-00	Adaptor to allow fitment of Oceaneering Tool
TL0017-3000-00	Adaptor to allow fitment of Petrobras Tool

