

ROV SHANK HOOK

TYPE HK5

Material : Alloy steel quenched and tempered
 Safety : 4 times
 Finish : Painted
 Certificates : Manufacturer certificate
 on request Proofload certificate

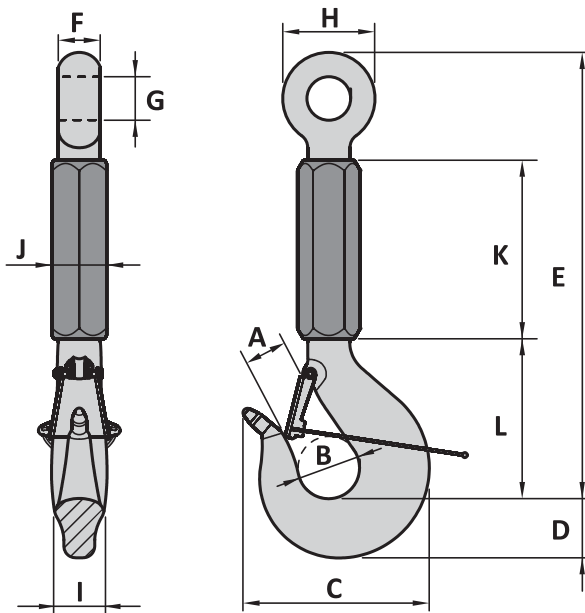

Type for Hook WLL 5 ton up to WLL 80 ton

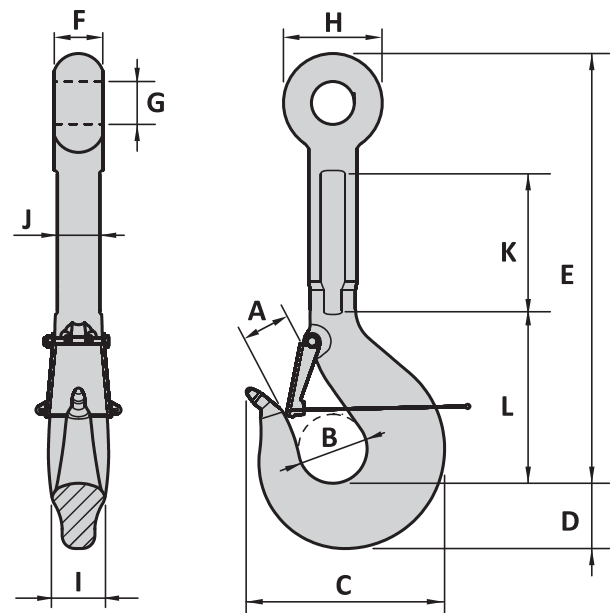

Type for Hook WLL 100 ton up to WLL 400 ton

Art. No.	WLL ton	MBL ton	A mm	B mm	C mm	D mm	E mm	F mm	G mm	H mm	I mm	J mm	K mm	L mm	Weight kg
53000005	5	20	35	50	161	40	515	34	31	68	32	45	250	150	7
53000012	12.5	50	40	63	200	58	565	45	40	90	45	60	260	180	12
53000016	16	64	45	70	224	67	610	48	44	102	53	60	280	190	18
53000025	25	100	50	80	248	75	650	56	52	105	60	70	270	230	22
53000032	32	128	60	90	288	85	800	65	60	140	67	80	360	265	34
53000040	40	160	70	100	316	95	820	70	70	150	75	85	330	285	45
53000050	50	200	75	112	343	106	850	75	72	160	85	100	350	285	62
53000063	63	252	85	125	376	118	900	85	85	180	95	110	360	322	79
53000080	80	320	100	140	418	132	950	100	85	210	106	120	290	390	108
53000100	100	400	110	160	462	150	1000	110	100	230	118	98	320	400	155
53000125	125	500	130	180	509	170	1050	125	100	260	132	106	280	450	207
53000160	160	640	140	200	584	190	1100	140	130	305	150	120	280	500	308
53000200	200	800	160	224	648	212	1200	160	130	350	170	136	280	560	367
53000250	250	1000	180	250	740	236	1200	180	145	370	190	150	300	630	460
53000320	300	1280	200	280	825	265	1250	200	160	405	212	165	300	700	650
53000400	400	1600	225	315	920	300	1300	220	185	465	236	180	300	800	900

Tolerance: Forged parts ± 5%, machined parts ± 1 mm

